

Patent Pending • Made in U.S.A.

 **LamCam™ — SlimCam™ 50mm**

www.anchorlamina.com
Check our website for the latest
technical information.

TABLE OF CONTENTS

Introduction.....	2
Aerial SlimCam™ Dimensions.....	4
Aerial SlimCam™ exploded view & parts list.....	6
Diemount SlimCam™ Dimensions.....	8
Diemount SlimCam™ exploded view & parts list.....	10

Anchor Lamina has made a commitment to the metal stamping industry by manufacturing and distributing a comprehensive collection of high quality products.

Lamina has long been known for expertise in producing precision products and has applied that knowledge to the design and production of cams with truly interchangeable parts. LamCams™ maintain consistency throughout standard lines available from bump cams to Aerial and Diemount cams to the Modular Styles.

Input from our customers has been, and continues to be, an important part of cam development and maintenance which assures Lamina's leadership position.

No other company surpasses our obligation to you, our customer, in supporting our cam products. We listen to your needs and respond when you require assistance.

Four tons of performance at a 1-1/2 ton price! Highest rated tonnage in the 50mm wide cam field!

- **Robust cam for light and medium duty applications**
- **High quality materials used throughout, including high-strength steel castings for major components**
- **Nitrogen return spring**
- **Mechanically interlocked slide**
- **Mounting/locating provisions include both square keys and dowel holes**
- **Meets or exceeds all of "NAAMS" cam requirements**
- **Dynamic load rating of 4 tons (35.6kN)**
- **True 50mm width**
- **Dual external positive return system**
- **Compact footprint**

Anchor Lamina introduces the true 50mm cam that meets NAAMS standards...

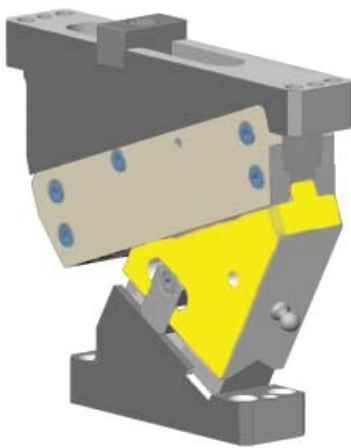

0° – 60° Aerial

Aerial configuration offered in 5° increments from 0° to 60° work angles

Diemount & Aerial

Shut Height = 225mm

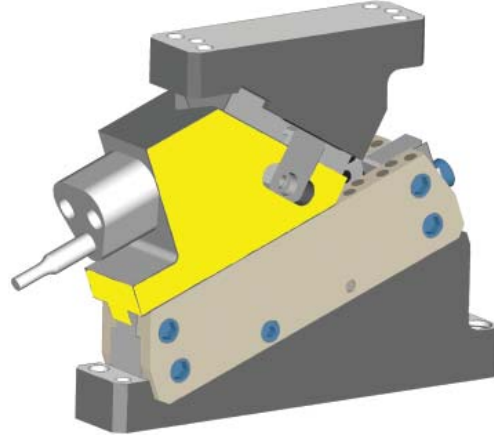

0° – 30° Diemount

Diemount configuration offered in 5° increments from 0° to 30° work angles

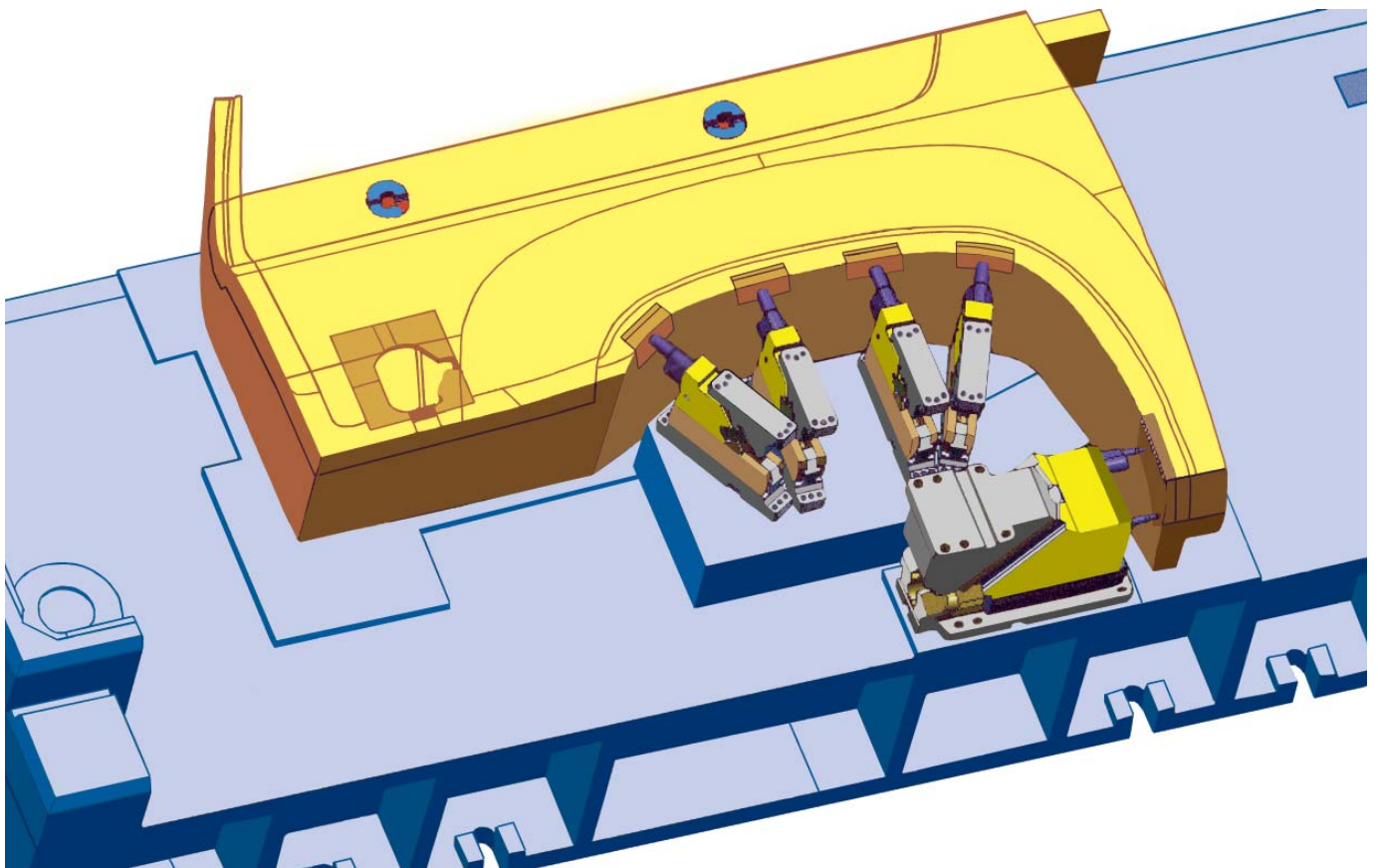

AERIAL SlimCam™ 50mm Series

AUTOMOTIVE METRIC
NAAMS STANDARD

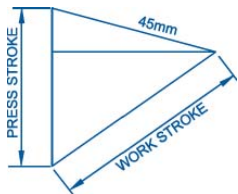

CAM DIAGRAM

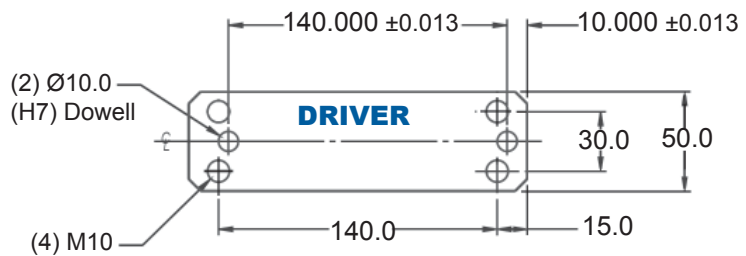
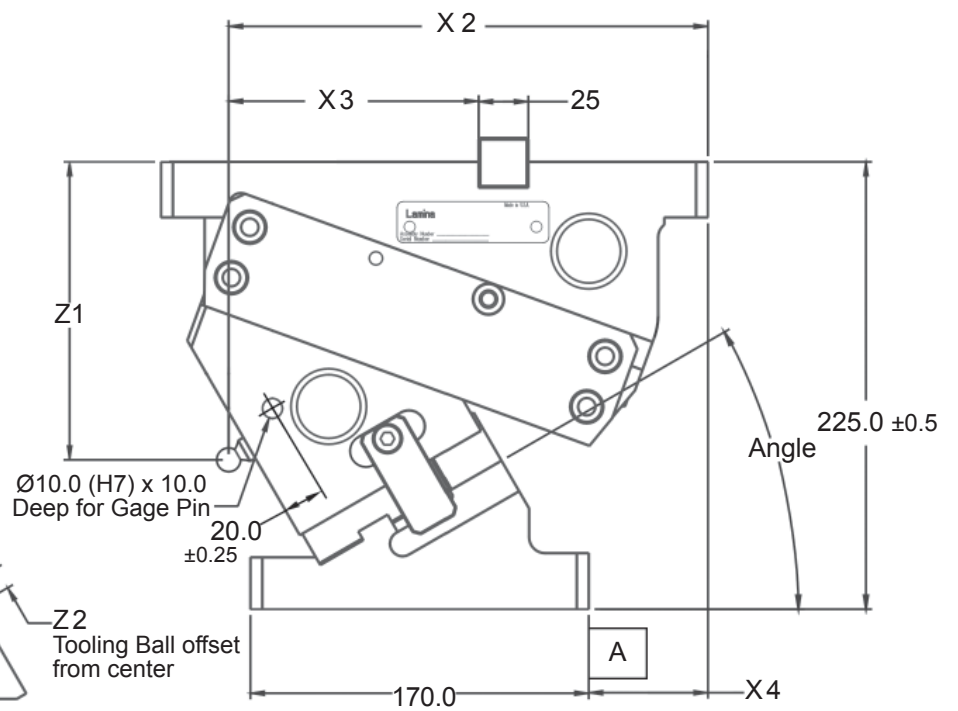
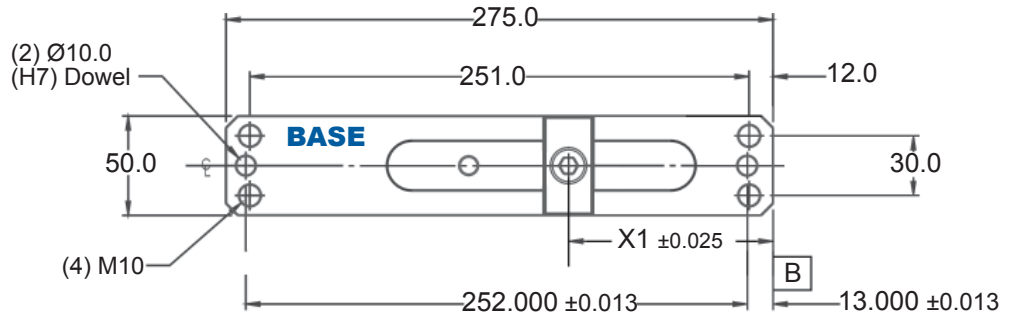
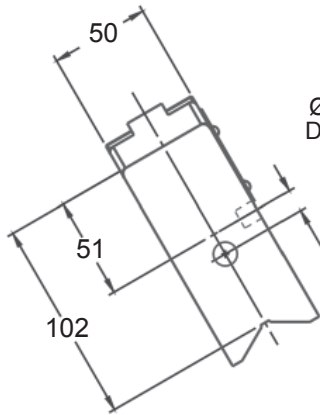
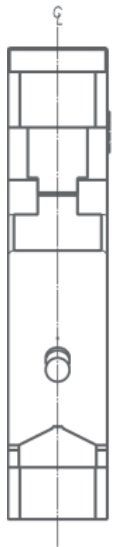

ANGLE	PRESS STROKE	WORK STROKE
0	34.5	28.9
5	34.6	31.9
10	35.0	35.0
15	35.7	38.2
20	36.7	41.5
25	38.0	45.0
30	39.8	48.8
35	42.1	53.7
40	45.0	57.9
45	48.8	63.4
50	53.6	70.0
55	67.9	78.2
60	77.9	90.0

SlimCam™ AERIAL CAM DIMENSIONS									
PART NUMBER	ANGLE	APPROX. WEIGHT		X1 (CL of Key)	X2 (NAAMS E)	X3 (NAAMS C)	X4 Base to Driver Datum	Z1 (NAAMS A)	Z2
		kg	lbs.						
NLA050000	0	20	44	102.6	270.6	155.5	122.0	120.0	-0.3
NLA050500	5	20	44	104.9	266.9	149.5	110.0	125.0	-4.1
NLA051000	10	20	44	105.9	263.4	145.0	102.0	130.0	2.6
NLA051500	15	18	40	101.8	254.8	140.5	89.0	135.0	0.0
NLA052000	20	18	40	107.0	254.0	134.5	81.0	140.0	-2.5
NLA052500	25	18	40	109.4	251.9	130.0	75.0	145.0	-4.2
NLA053000	30	18	40	102.9	240.9	125.5	60.0	150.0	-11.4
NLA053500	35	18	40	107.6	239.6	119.5	53.0	155.0	-7.0
NLA054000	40	18	40	92.9	220.4	115.0	37.0	160.0	-10.7
NLA054500	45	18	40	93.7	216.7	110.5	35.0	165.0	-8.1
NLA055000	50	18	40	93.4	211.9	106.0	28.0	170.0	-8.8
NLA055500	55	18	40	93.7	207.7	101.5	20.0	175.0	-5.0
NLA056000	60	18	40	89.4	200.4	98.5	18.0	180.0	-7.6

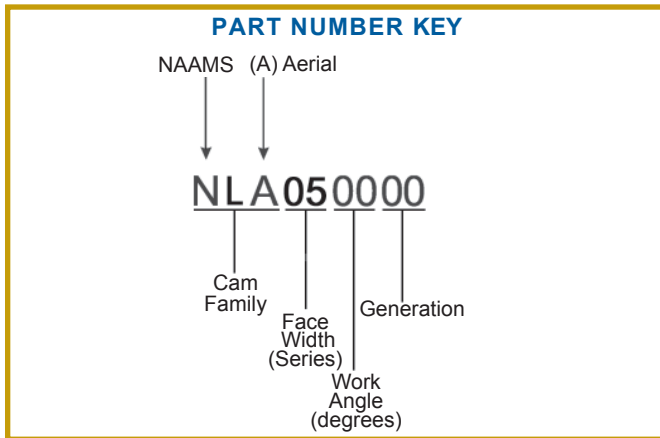

SLIDE RETURN SYSTEM

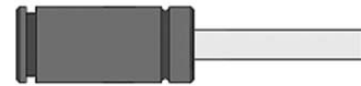

Nitrogen Gas Spring

The Nitrogen return system provides higher slide return forces for additional stripping boost.

SlimCam™ Series
PERFORMANCE GRAPH
(Based on .04mm wear on bronze)

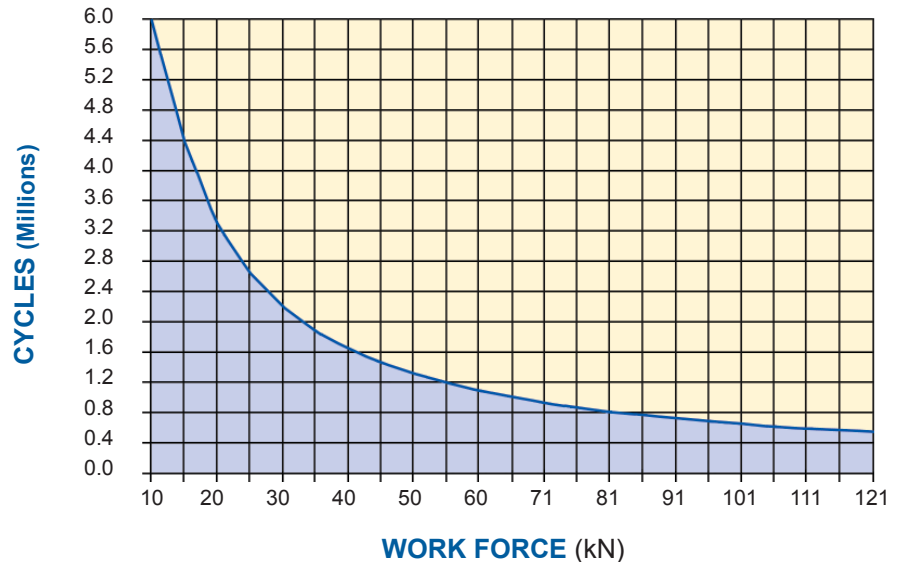

COMPONENT PARTS for SlimCam™ Series Aerial Cams

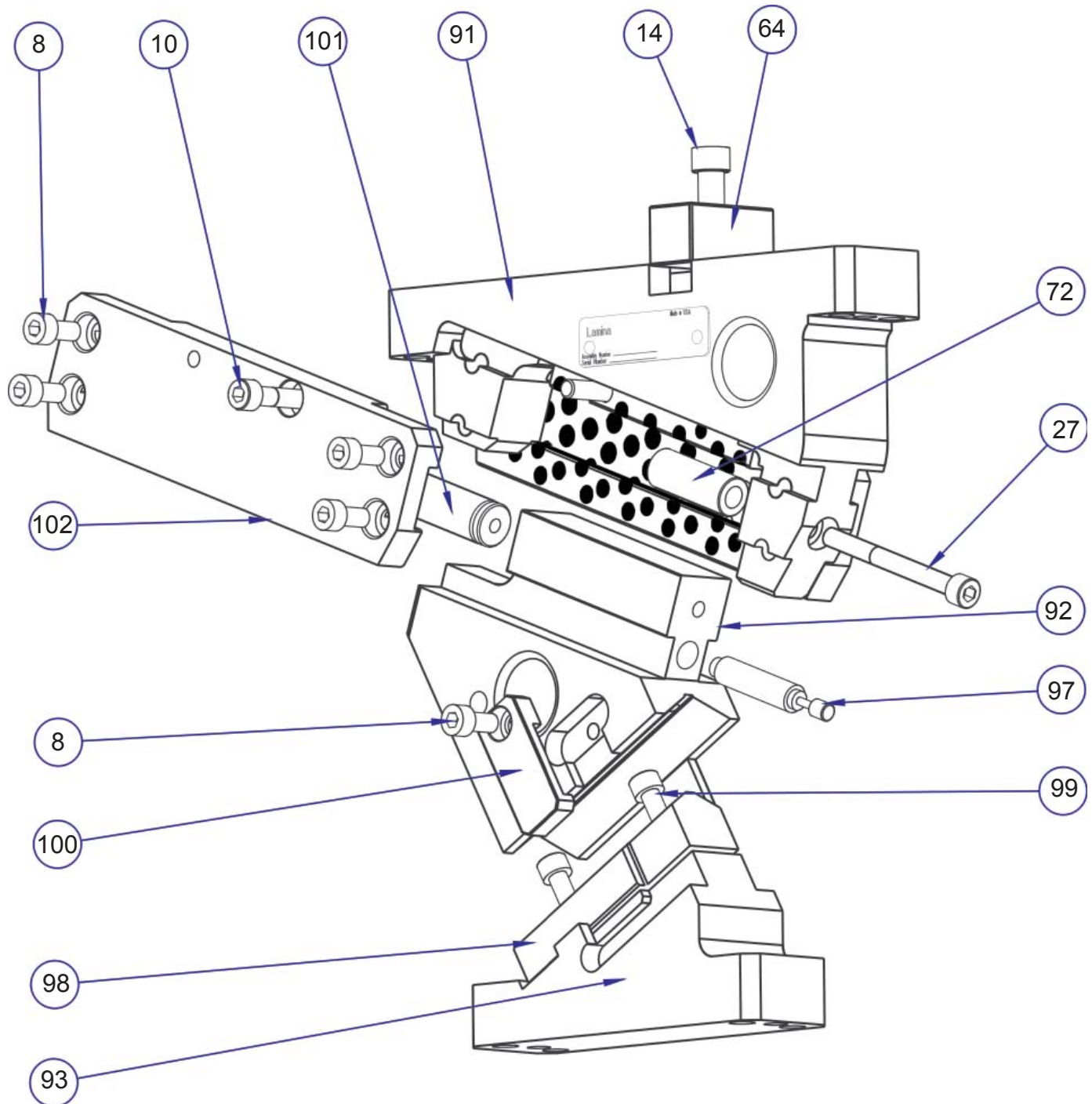

SlimCam™ AERIAL REPLACEMENT PARTS			
ITEM NUMBER	QUANTITY	DESCRIPTION	PART NUMBER
8	10	Soc. Hd. Cap Screw M8x1.25x16	F010809
10	2	Soc. Hd. Cap Screw M8x1.25x40	F010814
14	1	Soc. Hd. Cap Screw M10x1.5x25	F011011
27	1	Soc. Hd. Cap Screw M8x1.25x80	F010822
64	1	NAAMS Key 25x25x50	M082505
72	1	Lockout Spacer	NCM050008
91	1	Base (See Note 1)	NLA05@@@10
92	1	Slide (See Note 1)	NLA05@@@30
93	1	Driver (See Note 1)	NLA05@@@20
97	1	Shock Absorber	MC75M
98	1	V-Block	LCM050002
99	2	Soc. Hd. Cap Screw M8x1.25x25	F010811
100	2	Positive Return Bracket	LCM050001
101	1	Gas Spring	R19-050B
102	2	Keeper Plate	LCM050003

Note 1: Insert Angle (00,05,10 etc.) for @@ in part number.

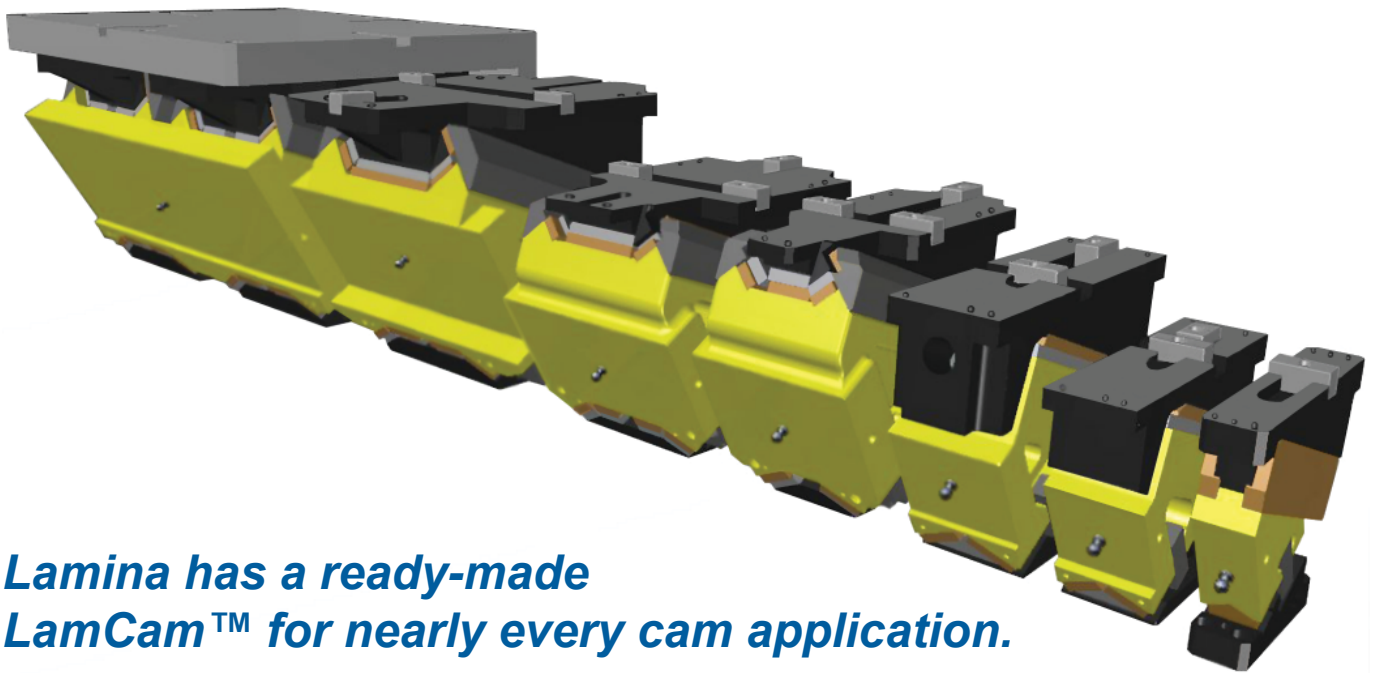

Lamina has a ready-made LamCam™ for nearly every cam application.

Look on our website www.anchorlamina.com for our entire line of ready-made Cams. Lamina also provides specials and custom-made Cams.

DIEMOUNT SlimCam™ 50mm Series

AUTOMOTIVE METRIC
NAAMS STANDARD

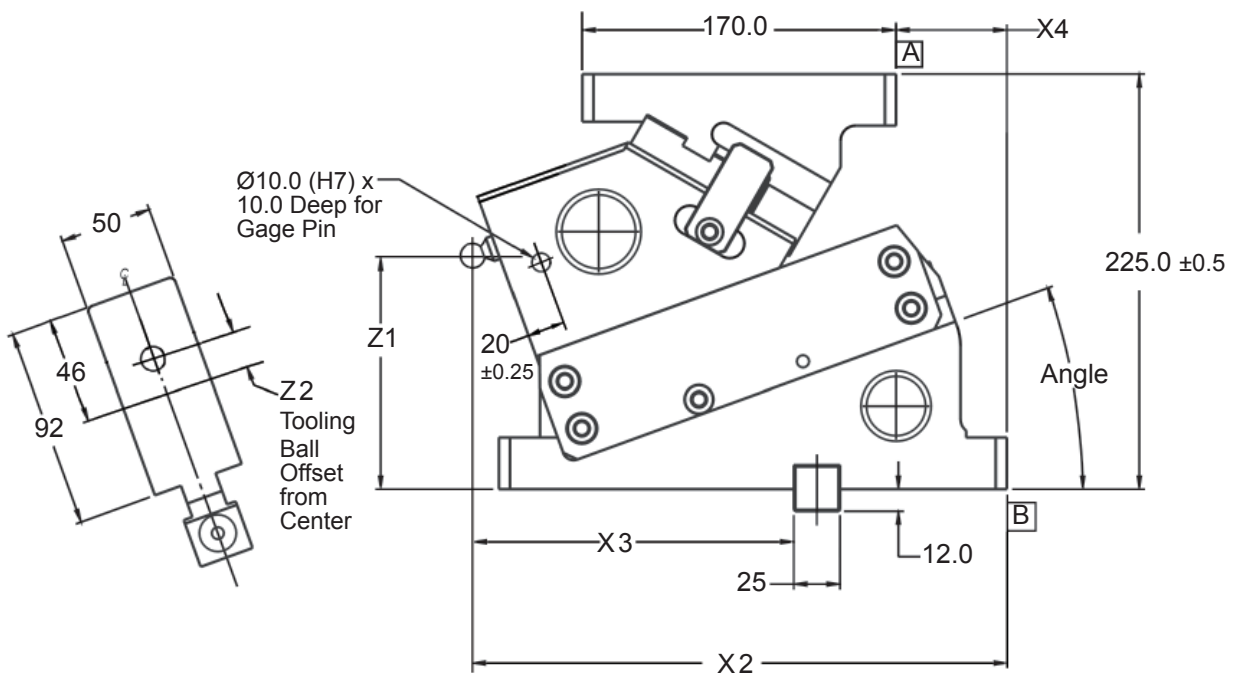
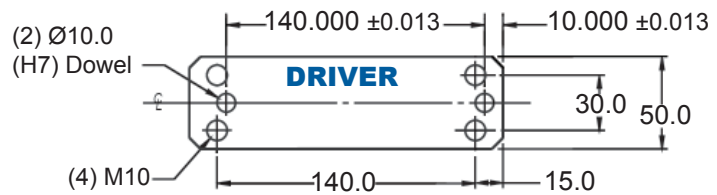
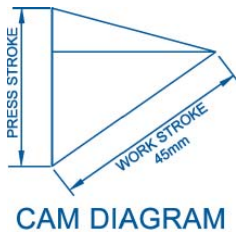

STROKE		
ANGLE	PRESS STROKE	WORK STROKE
0	53.6	45
5	48.8	45
10	45.0	45
15	42.1	45
20	39.8	45
25	38.0	45
30	36.7	45

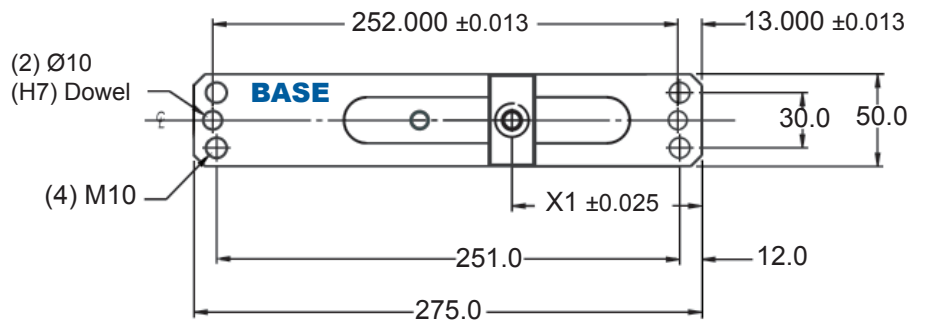

SlimCam™ DIEMOUNT CAM DIMENSIONS									
PART NUMBER	ANGLE	APPROX. WEIGHT		X1 (Class of Key)	X2 (NAAMS E)	X3 (NAAMS C)	X4 Base to Driver Datum	Z1 (NAAMS A)	Z2
		kg	lbs.						
NLD050000	0	20	44	93.4	262.0	156.1	28.0	160.0	11.0
NLD050500	5	19	42	93.7	275.0	158.9	35.0	150.0	9.8
NLD051000	10	20	43	92.9	269.2	163.8	37.0	140.0	11.0
NLD051500	15	18	40	107.6	284.6	164.5	53.0	135.0	12.2
NLD052000	20	18	40	102.9	289.1	173.7	60.0	130.0	14.3
NLD052500	25	18	40	109.4	289.3	167.4	75.0	115.0	6.7
NLD053000	30	18	40	107.0	286.1	166.6	81.0	105.0	2.7

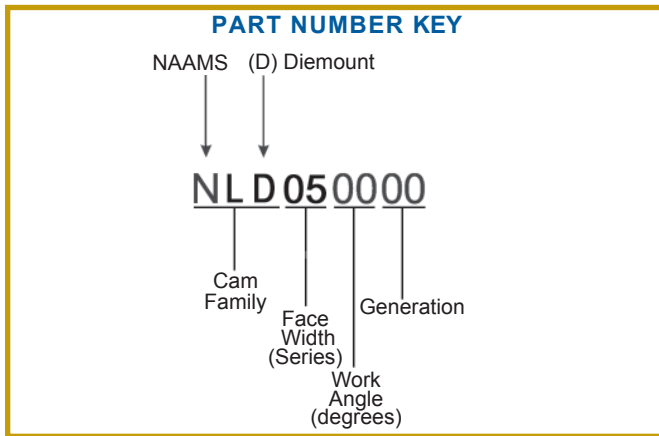

SLIDE RETURN SYSTEM

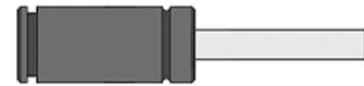

Nitrogen Gas Spring

The Nitrogen return system provides higher slide return forces for additional stripping boost.

SlimCam™ Series
PERFORMANCE GRAPH
(Based on .04mm wear on bronze)

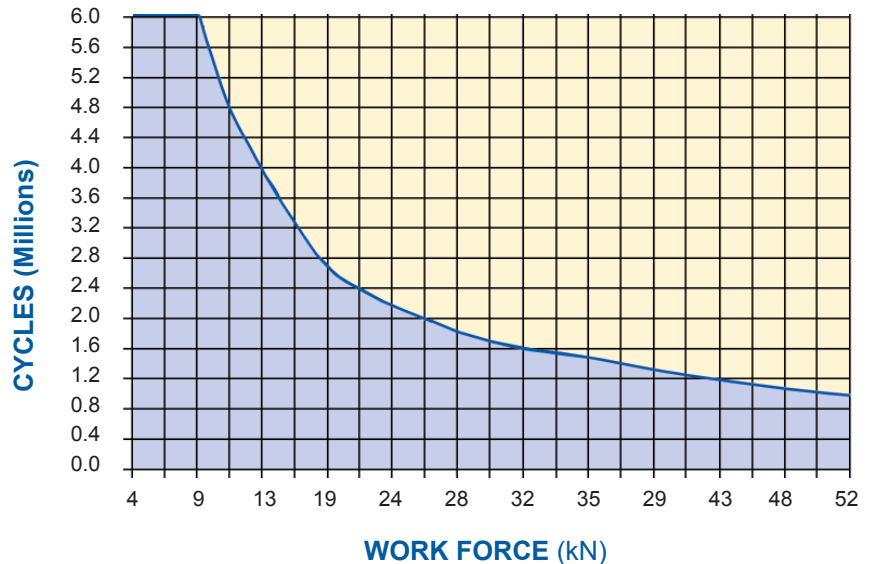

COMPONENT PARTS for SlimCam™ Series Diemount Cams

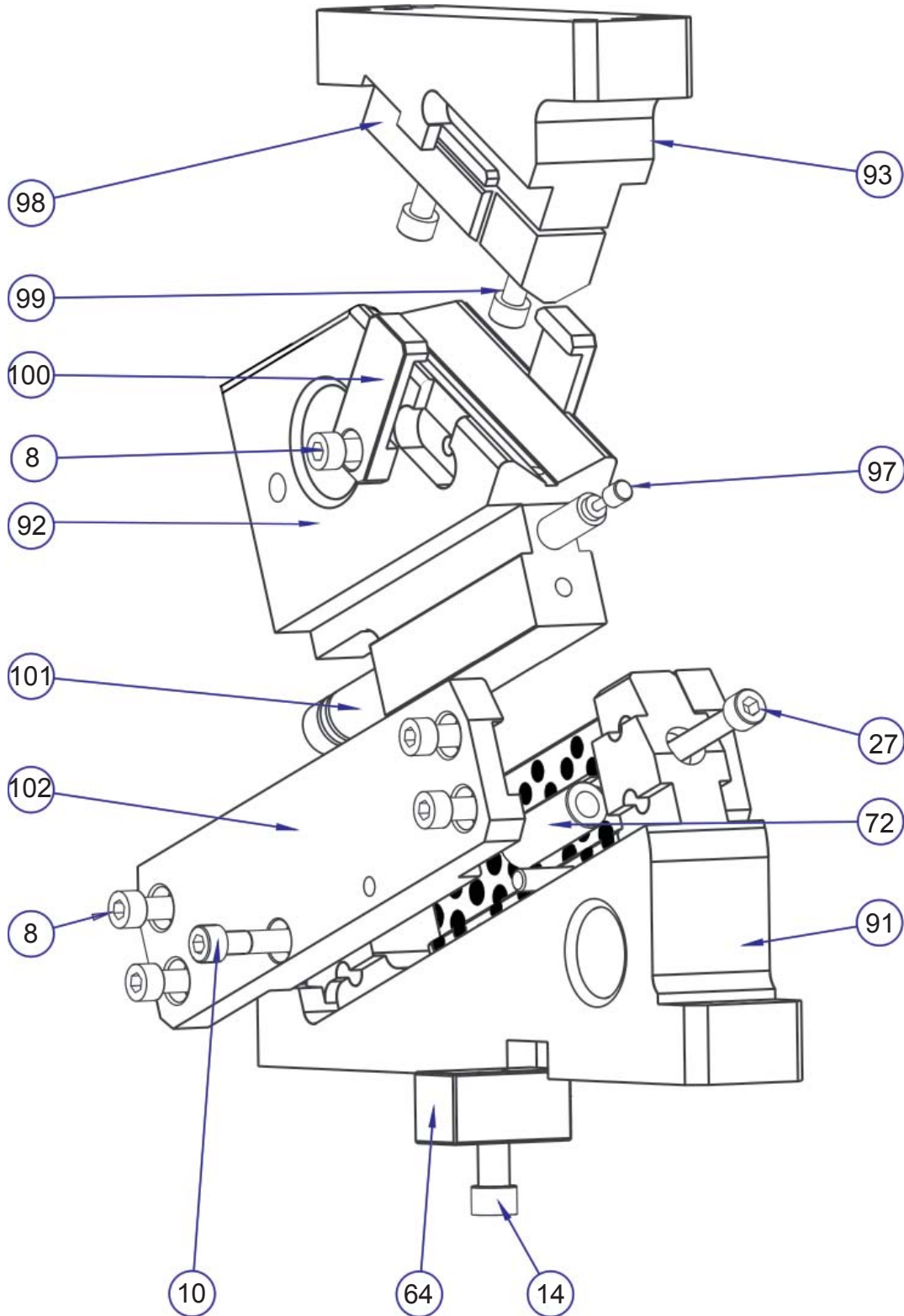

SlimCam™ DIEMOUNT REPLACEMENT PARTS			
ITEM NUMBER	QUANTITY	DESCRIPTION	PART NUMBER
8	10	Soc. Hd. Cap Screw M8x1.25x16	F010809
10	2	Soc. Hd Cap Screw M8x1.25x40	F010814
14	1	Soc. Hd. Cap Screw M10x1.5x25	F011011
27	1	Soc. Hd. Cap Screw M8x1.25x80	F010822
64	1	NAAMS Key 25x25x50	M082505
72	1	Lockout Spacer	NCM050008
91	1	Base (See Note 1)	NLA05@@@10
92	1	Slide (See Note 1)	NLD05@@@30
93	1	Driver (See Note 1)	NLA05@@@20
97	1	Shock Absorber	MC75M
98	1	V-Block	LCM050002
99	2	Soc. Hd. Cap Screw M8x1.25x25	F010811
100	2	Positive Return Bracket	LCM050001
101	1	Gas Spring	R19-050B
102	2	Keeper Plate	LCM050003

Note 1: For @@@ in part numbers insert: (50 for 0°); (45 for 5°); (40 for 10°); (35 for 15°); (30 for 20°); (25 for 25°) and (20 for 30°).

Check out these die mount cams.

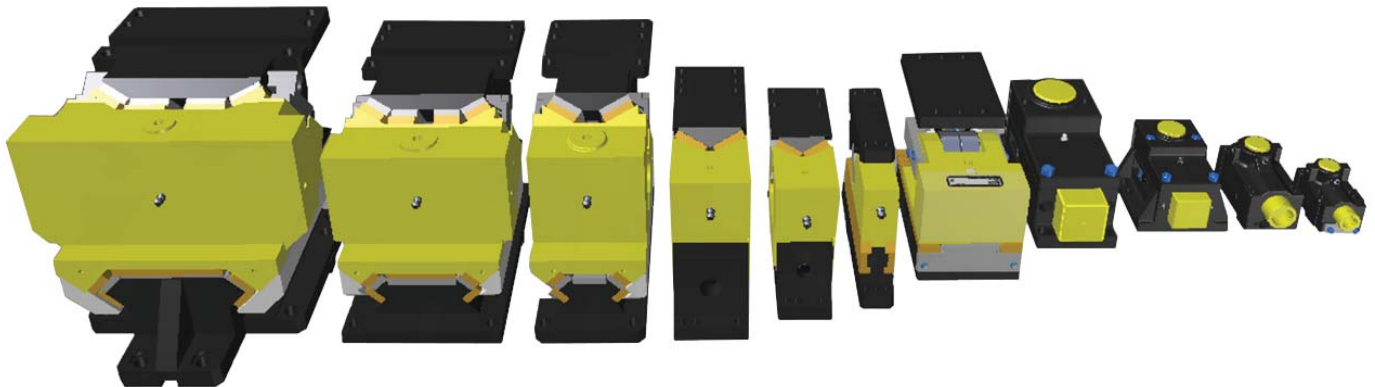

From 300mm to 50mm Standard Cams, SlimCam™, and RollerCam to our unique Bump Cams. Diemount modular cams (500mm - 1200 width) are not pictured.

Anchor Lamina takes great pride in the cam products that carry the LamCam™ name. We stand behind those products by fully servicing them with Lamina authorized interchangeable component parts manufactured for or by Lamina expressly.

Committed to Quality & Customer Satisfaction

Anchor Lamina is committed to be the “customer focused” world-class supplier of choice to the metal-working and plastics forming industry.

We will help our customers to compete globally by providing innovative and value added products and services.

Distributed by:



Lamina Components

38505 Country Club Drive Suite 100

Farmington Hills, MI USA 48331

Tel: 248-489-9122, 800-652-6462

Fax: 248-553-6842, 800-406-4410

E-Mail: sales@lamina.com

www.anchorlamina.com

