



DIEMAX™ L DIE SPRINGS

Die Spring Basics

A die spring is a highly engineered mechanical spring with specific wire designs that stores energy elastically by resisting movement when pressure is applied. The desired wire segment is selected to produce the maximum amount of force within a minimal amount of space.

Altering Die Springs Each die spring is carefully engineered to perform within specific applications. Under no circumstances should you alter a die spring. Altering a die spring will change its designed characteristics and allows additional stresses to occur causing early failure. Grinding on the die spring not only changes the spring's original properties, but the heat from grinding can change the temper of the material and negatively affect the spring's performance.

Compressed Length The sum of the preload travel and operating travel.

Corrosion Frequently, die spring failure can be traced to corrosive elements which affect the surface of the spring's material, causing premature failure. Be aware of conditions that may affect the spring's surface such as rust, lubricants, soaps, and chemicals. Clean, protected die springs provide the best performance.

Cycle Rate The more rapidly a spring is cycled, the greater the need to operate in the recommended long life deflections from the catalog.

Die Spring Guidance Make sure that the hole size and/or rod size match the die spring's operating dimensions.

Duty Ranges We offer 4 separate duty ranges to best suit your applications – Medium Duty, Medium Heavy Duty, Heavy Duty, and Extra Heavy Duty. Do not mix springs of different duties.

Free Length The length of the spring without any load or force applied.

Hole Diameter Die springs are designed to be used in a hole dimension as indicated in the catalog. The actual O.D. will be somewhat smaller to prevent interference.

Material In our case, the spring material is High Tensile Strength Chrome Silicon Material. We use an optimal rectangular wire design. The maximum rated service temperature is 425°F.

Operating Travel Operating travel is the deflection of the spring where it is operating between the preload and the total travel of the spring during operation. This is the area where the actual work is performed.

Preload The initial force which is applied to a die spring. Preload is recommended to compress the first coils at each end where additional stresses are present because of the turn-down of the end coils. Applying a preload will extend the life of the spring.

Quality Our die springs are manufactured in an ISO9001-2008 facility.

Rates Die spring rates are normally listed as *Pounds per Inch of deflection* (i.e. 60 pounds load per inch.) As a die spring is deflected, the loads will increase for the amount of travel it is deflected. That is, a spring with a 60lb/inch rate will produce 60 lbs of resistance at 1" of travel, 120 lbs. at 2" of travel, etc. For purposes of simplification, the loads in our catalog are shown in pounds needed to deflect a spring 1/10th of an inch. Simply multiply the rates given by 10 to determine the actual spring rate.

Rod Diameter Die springs are designed to fit over a rod for guidance and the actual I.D. of the spring is actually somewhat larger to fit over a rod without interference.

Solid Height Solid height is the height of the spring when all of the coils are totally collapsed to solid. You never want to operate a die spring close to this condition.

MADE IN AMERICA

www.anchorlamina.com

Check our website for the latest technical information.

Inch Die Springs

TABLE OF CONTENTS

PAGE NUMBER

Medium Duty – Blue	2
Medium Heavy Duty – Red	4
Heavy Duty – Gold	6
Extra Heavy Duty – Green	8
Spring Accessories	10
Special Heavy Duty Compression Springs	12

Die Springs Product Features

- ◆ For same day shipments, we stock them so you don't have to
- ◆ Inch sizes manufactured to industry standard colors
- ◆ Yields reliable, trouble-free performance
- ◆ Manufactured in an ISO 9001:2008 certified facility
- ◆ Manufactured from spring-quality Chromium Silicon alloy, high-tensile strength steel in accordance with ASTM A1000-99 specifications
- ◆ Optimal rectangular wire design



MEDIUM DUTY
Color Coded
Blue Stripe

MEDIUM HEAVY DUTY
Color Coded
Red Stripe

HEAVY DUTY
Color Coded
Gold Stripe

EXTRA HEAVY DUTY
Color Coded
Green Stripe

Medium Duty Die Springs

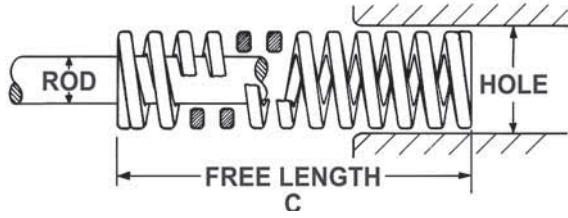

Color coded **BLUE STRIPE**

Hole Diam. (in)	Rod Diam. (in)	Free Length (in)	Wire Size (in)	CATALOG NUMBER	Pounds @ 1/10 inch defl.	Total Deflection Recommended for Long Life (25% of C)		Total Deflection Recommended for Avg. Life (35% of C)		Maximum Operating Deflection (40% of C)		* Max. Comp. Length (in)
						Load lbs.	Defl. in.	Load lbs.	Defl. in.	Load lbs.	Defl. in.	
3/8	3/16	1.00	0.040 X 0.070	M100L	6.2	15.5	0.25	21.7	0.35	24.8	0.40	0.48
		1.25		M100AL	5.3	16.6	0.31	23.2	0.44	26.5	0.50	0.56
		1.50		M101L	4.2	15.6	0.38	21.8	0.53	24.9	0.60	0.68
		1.75		M101AL	3.5	15.3	0.44	21.4	0.61	24.5	0.70	0.78
		2.00		M102L	2.9	14.5	0.50	20.3	0.70	23.2	0.80	0.94
		2.50		M103L	2.4	15.3	0.63	21.4	0.88	24.4	1.00	1.12
		3.00		M104L	2.1	15.8	0.75	22.1	1.05	25.2	1.20	1.40
		12.00		M105L	0.6	16.8	3.00	23.5	4.20	26.9	4.80	5.11
1/2	9/32	1.00	0.052 X 0.095	M110L	10.7	26.8	0.25	37.5	0.35	42.8	0.40	0.45
		1.25		M110AL	8.2	25.6	0.31	35.9	0.44	41.0	0.50	0.55
		1.50		M111L	6.8	25.5	0.38	35.7	0.53	40.8	0.60	0.66
		1.75		M111AL	6.0	26.3	0.44	36.8	0.61	42.0	0.70	0.73
		2.00		M112L	5.3	26.5	0.50	37.1	0.70	42.4	0.80	0.82
		2.50		M113L	4.3	26.9	0.63	37.6	0.88	43.0	1.00	1.02
		3.00		M114L	3.4	25.5	0.75	35.7	1.05	40.8	1.20	1.25
		3.50		M115L	2.9	25.4	0.88	35.5	1.23	40.6	1.40	1.42
		4.50		M115AL	2.4	27.0	1.13	37.8	1.58	43.2	1.80	1.82
		5.50		M115BL	2.0	27.5	1.38	38.5	1.93	44.0	2.20	2.22
		6.50		M115CL	1.4	22.8	1.63	31.9	2.28	36.4	2.60	2.65
		7.50		M115DL	1.2	22.5	1.88	31.5	2.63	36.0	3.00	3.27
12.00	M116L	0.7	21.0	3.00	29.4	4.20	33.6	4.80	5.24			
5/8	11/32	1.00	0.068 X 0.117	M120L	17.0	42.5	0.25	59.5	0.35	68.0	0.40	0.50
		1.25		M120AL	13.0	40.6	0.31	56.9	0.44	65.0	0.50	0.62
		1.50		M121L	11.1	41.6	0.38	58.3	0.53	66.6	0.60	0.69
		1.75		M121AL	9.6	42.0	0.44	58.8	0.61	67.2	0.70	0.80
		2.00		M122L	8.8	44.0	0.50	61.6	0.70	70.4	0.80	0.89
		2.50		M123L	6.3	39.4	0.63	55.1	0.88	63.0	1.00	1.16
		3.00		M124L	5.6	42.0	0.75	58.8	1.05	67.2	1.20	1.27
		3.50		M125L	4.8	42.0	0.88	58.8	1.23	67.2	1.40	1.46
		4.00		M126L	4.4	44.0	1.00	61.6	1.40	70.4	1.60	1.65
		12.00		M127L	1.5	45.6	3.00	63.8	4.20	73.0	4.80	4.83
3/4	3/8	1.00	0.085 X 0.155	M1L	31.8	79.5	0.25	111.3	0.35	127.2	0.40	0.50
		1.25		M1AL	25.6	80.0	0.31	112.0	0.44	128.0	0.50	0.65
		1.50		M2L	20.0	75.0	0.38	105.0	0.53	120.0	0.60	0.77
		1.75		M2AL	17.6	77.0	0.44	107.8	0.61	123.2	0.70	0.88
		2.00		M3L	14.4	72.0	0.50	100.8	0.70	115.2	0.80	1.03
		2.50		M4L	12.0	75.0	0.63	105.0	0.88	120.0	1.00	1.28
		3.00		M5L	9.6	72.0	0.75	100.8	1.05	115.2	1.20	1.49
		3.50		M6L	8.0	70.0	0.88	98.0	1.23	112.0	1.40	1.74
		4.00		M7L	7.2	72.0	1.00	100.8	1.40	115.2	1.60	1.99
		4.50		M8L	6.4	72.0	1.13	100.8	1.58	115.2	1.80	2.24
		5.00		M9L	6.0	75.0	1.25	105.0	1.75	120.0	2.00	2.48
		5.50		M10L	5.5	75.6	1.38	105.9	1.93	121.0	2.20	2.72
		6.00		M11L	5.0	75.0	1.50	105.0	2.10	120.0	2.40	2.97
		6.50		M11BL	4.5	73.1	1.63	102.4	2.28	117.0	2.60	3.20
		7.50		M11CL	3.8	71.3	1.88	99.8	2.63	114.0	3.00	3.64
12.00	M11AL	2.4	72.0	3.00	100.8	4.20	115.2	4.80	5.84			

* NOTE: For design purposes only. We do not recommend deflecting a spring to maximum deflection.

Inch Standard

Hole Diam. (in)	Rod Diam. (in)	Free Length (in)	Wire Size (in)	CATALOG NUMBER	Pounds @ 1/10 inch defl.	Total Deflection Recommended for Long Life (25% of C)		Total Deflection Recommended for Avg. Life (35% of C)		Maximum Operating Deflection (40% of C)		* Max. Comp. Length (in)
						Load lbs.	Defl. in.	Load lbs.	Defl. in.	Load lbs.	Defl. in.	
1	1/2	1.00	0.105 X 0.212	M12L	55.0	137.5	0.25	192.5	0.35	220.0	0.40	0.51
		1.25		M12AL	45.0	140.6	0.31	196.9	0.44	225.0	0.50	0.66
		1.50		M13L	35.4	132.8	0.38	185.9	0.53	212.4	0.60	0.78
		1.75		M13AL	30.0	131.3	0.44	183.8	0.61	210.0	0.70	0.90
		2.00		M14L	26.0	130.0	0.50	182.0	0.70	208.0	0.80	1.02
		2.50		M15L	20.2	126.3	0.63	176.8	0.88	202.0	1.00	1.27
		3.00		M16L	16.5	123.8	0.75	173.3	1.05	198.0	1.20	1.50
		3.50		M17L	15.0	131.3	0.88	183.8	1.23	210.0	1.40	1.75
		4.00		M18L	12.0	120.0	1.00	168.0	1.40	192.0	1.60	2.00
		4.50		M19L	10.5	118.1	1.13	165.4	1.58	189.0	1.80	2.25
		5.00		M20L	9.6	120.0	1.25	168.0	1.75	192.0	2.00	2.49
		5.50		M21L	8.8	121.0	1.38	169.4	1.93	193.6	2.20	2.74
		6.00		M22L	8.0	120.0	1.50	168.0	2.10	192.0	2.40	2.96
		7.00		M23L	7.2	126.0	1.75	176.4	2.45	201.6	2.80	3.48
8.00	M24L	6.0	120.0	2.00	168.0	2.80	192.0	3.20	3.86			
12.00	M24AL	4.0	120.0	3.00	168.0	4.20	192.0	4.80	5.76			
1-1/4	5/8	1.50	0.125 X 0.270	M36L	51.0	191.3	0.38	267.8	0.53	306.0	0.60	0.75
		1.75		M36AL	42.4	185.5	0.44	259.7	0.61	296.8	0.70	0.88
		2.00		M37L	36.0	180.0	0.50	252.0	0.70	288.0	0.80	1.05
		2.50		M38L	28.8	180.0	0.63	252.0	0.88	288.0	1.00	1.25
		3.00		M39L	24.0	180.0	0.75	252.0	1.05	288.0	1.20	1.46
		3.50		M40L	20.0	175.0	0.88	245.0	1.23	280.0	1.40	1.70
		4.00		M41L	17.6	176.0	1.00	246.4	1.40	281.6	1.60	1.95
		4.50		M42L	16.0	180.0	1.13	252.0	1.58	288.0	1.80	2.20
		5.00		M43L	13.6	170.0	1.25	238.0	1.75	272.0	2.00	2.44
		5.50		M44L	12.8	176.0	1.38	246.4	1.93	281.6	2.20	2.72
		6.00		M45L	12.0	180.0	1.50	252.0	2.10	288.0	2.40	2.98
		7.00		M46L	10.4	182.0	1.75	254.8	2.45	291.2	2.80	3.50
		8.00		M47L	8.8	176.0	2.00	246.4	2.80	281.6	3.20	3.98
		10.00		M48L	7.2	180.0	2.50	252.0	3.50	288.0	4.00	4.98
12.00	M48AL	6.0	180.0	3.00	252.0	4.20	288.0	4.80	5.98			
1-1/2	3/4	2.00	0.158 X 0.315	M49L	54.7	273.5	0.50	382.9	0.70	437.6	0.80	1.03
		2.50		M50L	44.7	279.4	0.63	391.1	0.88	447.0	1.00	1.27
		3.00		M51L	36.0	270.0	0.75	378.0	1.05	432.0	1.20	1.52
		3.50		M52L	30.0	262.5	0.88	367.5	1.23	420.0	1.40	1.74
		4.00		M53L	27.0	270.0	1.00	378.0	1.40	432.0	1.60	1.99
		4.50		M54L	23.0	258.8	1.13	362.3	1.58	414.0	1.80	2.22
		5.00		M55L	21.0	262.5	1.25	367.5	1.75	420.0	2.00	2.46
		5.50		M55AL	18.5	254.4	1.38	356.1	1.93	407.0	2.20	2.72
		6.00		M56L	17.0	255.0	1.50	357.0	2.10	408.0	2.40	2.96
		7.00		M56AL	14.5	253.8	1.75	355.3	2.45	406.0	2.80	3.40
		8.00		M57L	12.8	256.0	2.00	358.4	2.80	409.6	3.20	3.90
		10.00		M58L	10.0	250.0	2.50	350.0	3.50	400.0	4.00	4.86
		12.00		M58AL	8.2	246.0	3.00	344.4	4.20	393.6	4.80	5.86
		2		1	2.50	0.215 X 0.445	M70L	100.0	625.0	0.63	875.0	0.88
3.00	M71L		83.0		622.5		0.75	871.5	1.05	996.0	1.20	1.58
3.50	M72L		65.8		575.8		0.88	806.1	1.23	921.2	1.40	1.84
4.00	M73L		60.0		600.0		1.00	840.0	1.40	960.0	1.60	2.08
4.50	M74L		53.0		596.3		1.13	834.8	1.58	954.0	1.80	2.20
5.00	M75L		47.0		587.5		1.25	822.5	1.75	940.0	2.00	2.58
5.50	M76L		39.8		547.3		1.38	766.2	1.93	875.6	2.20	2.88
6.00	M77L		39.0		585.0		1.50	819.0	2.10	936.0	2.40	3.03
7.00	M79L		31.6		553.0		1.75	774.2	2.45	884.8	2.80	3.58
8.00	M80L		28.5		570.0		2.00	798.0	2.80	912.0	3.20	4.05
10.00	M82L		20.8		520.0		2.50	728.0	3.50	832.0	4.00	5.00
12.00	M83L		17.5		525.0		3.00	735.0	4.20	840.0	4.80	6.17

* NOTE: For design purposes only. We do not recommend deflecting a spring to maximum deflection.

Medium Heavy Duty Die Springs

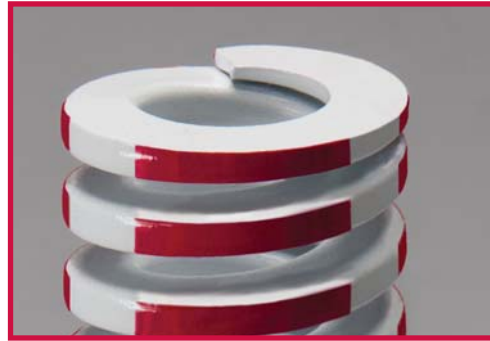
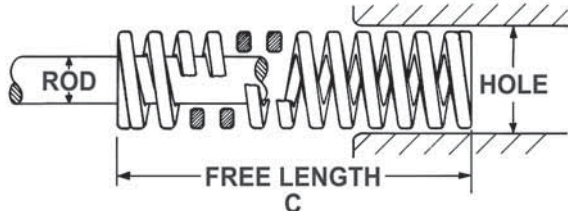

Color coded **RED STRIPE**

Hole Diam. (in)	Rod Diam. (in)	Free Length (in)	Wire Size (in)	CATALOG NUMBER	Pounds @ 1/10 inch defl.	Total Deflection Recommended for Long Life (20% of C)		Total Deflection Recommended for Avg. Life (25% of C)		Maximum Operating Deflection (35% of C)		* Max. Comp. Length (in)
						Load lbs.	Defl. in.	Load lbs.	Defl. in.	Load lbs.	Defl. in.	
3/8	3/16	1.00	0.045 X 0.070	MHC100L	9.0	18.0	0.20	22.5	0.25	31.5	0.35	0.58
		1.25		MHC100AL	7.3	18.3	0.25	22.8	0.31	31.9	0.44	0.71
		1.50		MHC101L	6.7	20.1	0.30	25.1	0.38	35.2	0.53	0.85
		1.75		MHC101AL	5.7	20.0	0.35	24.9	0.44	34.9	0.61	0.95
		2.00		MHC102L	5.0	20.0	0.40	25.0	0.50	35.0	0.70	1.09
		2.50		MHC103L	4.0	20.0	0.50	25.0	0.63	35.0	0.88	1.36
		3.00		MHC104L	3.0	18.0	0.60	22.5	0.75	31.5	1.05	1.69
	12.00	MHC106L	0.8	19.2	2.40	24.0	3.00	33.6	4.20	6.46		
1/2	9/32	1.00	0.060 X 0.095	MHC110L	16.6	33.2	0.20	41.5	0.25	58.1	0.35	0.50
		1.25		MHC110AL	13.0	32.5	0.25	40.6	0.31	56.9	0.44	0.61
		1.50		MHC111L	9.9	29.7	0.30	37.1	0.38	52.0	0.53	0.72
		1.75		MHC111AL	8.5	29.8	0.35	37.2	0.44	52.1	0.61	0.84
		2.00		MHC112L	7.5	30.0	0.40	37.5	0.50	52.5	0.70	0.95
		2.50		MHC113L	6.0	30.0	0.50	37.5	0.63	52.5	0.88	1.18
		3.00		MHC114L	5.5	33.0	0.60	41.3	0.75	57.8	1.05	1.40
		3.50		MHC115L	4.0	28.0	0.70	35.0	0.88	49.0	1.23	1.68
	12.00	MHC117L	1.2	28.8	2.40	36.0	3.00	50.4	4.20	5.68		
5/8	11/32	1.00	0.086 X 0.112	MHC120L	30.0	60.0	0.20	75.0	0.25	105.0	0.35	0.56
		1.25		MHC120AL	21.5	53.8	0.25	67.2	0.31	94.1	0.44	0.70
		1.50		MHC121L	19.2	57.6	0.30	72.0	0.38	100.8	0.53	0.79
		1.75		MHC121AL	16.8	58.8	0.35	73.5	0.44	102.9	0.61	0.92
		2.00		MHC122L	14.8	59.2	0.40	74.0	0.50	103.6	0.70	1.00
		2.50		MHC123L	11.5	57.5	0.50	71.9	0.63	100.6	0.88	1.22
		3.00		MHC124L	10.0	60.0	0.60	75.0	0.75	105.0	1.05	1.43
		3.50		MHC125L	8.5	59.5	0.70	74.4	0.88	104.1	1.23	1.69
		4.00		MHC126L	7.6	60.8	0.80	76.0	1.00	106.4	1.40	1.92
	12.00	MHC127L	2.6	62.4	2.40	78.0	3.00	109.2	4.20	5.70		
3/4	3/8	1.00	0.100 X 0.155	MHC1L	50.0	100.0	0.20	125.0	0.25	175.0	0.35	0.58
		1.25		MHC1AL	38.0	95.0	0.25	118.8	0.31	166.3	0.44	0.72
		1.50		MHC2L	32.0	96.0	0.30	120.0	0.38	168.0	0.53	0.87
		1.75		MHC2AL	28.5	99.8	0.35	124.7	0.44	174.6	0.61	1.02
		2.00		MHC3L	24.8	99.2	0.40	124.0	0.50	173.6	0.70	1.16
		2.50		MHC4L	19.2	96.0	0.50	120.0	0.63	168.0	0.88	1.46
		3.00		MHC5L	14.4	86.4	0.60	108.0	0.75	151.2	1.05	1.74
		3.50		MHC6L	12.8	89.6	0.70	112.0	0.88	156.8	1.23	2.02
		4.00		MHC7L	12.0	96.0	0.80	120.0	1.00	168.0	1.40	2.31
		4.50		MHC8L	11.0	99.0	0.90	123.8	1.13	173.3	1.58	2.62
		5.00		MHC9L	9.0	90.0	1.00	112.5	1.25	157.5	1.75	2.86
		5.50		MHC10L	8.0	88.0	1.10	110.0	1.38	154.0	1.93	3.15
		6.00		MHC11L	7.5	90.0	1.20	112.5	1.50	157.5	2.10	3.45
				12.00	MHC11AL	3.6	86.4	2.40	108.0	3.00	151.2	4.20

* NOTE: For design purposes only. We do not recommend deflecting a spring to maximum deflection.

Inch Standard

Hole Diam. (in)	Rod Diam. (in)	Free Length (in)	Wire Size (in)	CATALOG NUMBER	Pounds @ 1/10 inch defl.	Total Deflection Recommended for Long Life (20% of C)		Total Deflection Recommended for Avg. Life (25% of C)		Maximum Operating Deflection (35% of C)		* Max. Comp. Length (in)
						Load lbs.	Defl. in.	Load lbs.	Defl. in.	Load lbs.	Defl. in.	
1	1/2	1.00	0.125 X 0.214	MHC12L	76.0	152.0	0.20	190.0	0.25	266.0	0.35	0.61
		1.25		MHC12AL	62.4	156.0	0.25	195.0	0.31	273.0	0.44	0.75
		1.50		MHC13L	49.6	148.8	0.30	186.0	0.38	260.4	0.53	0.89
		1.75		MHC13AL	44.0	154.0	0.35	192.5	0.44	269.5	0.61	1.02
		2.00		MHC14L	40.0	160.0	0.40	200.0	0.50	280.0	0.70	1.15
		2.50		MHC15L	31.0	155.0	0.50	193.8	0.63	271.3	0.88	1.44
		3.00		MHC16L	25.0	150.0	0.60	187.5	0.75	262.5	1.05	1.73
		3.50		MHC17L	21.6	151.2	0.70	189.0	0.88	264.6	1.23	2.02
		4.00		MHC18L	18.4	147.2	0.80	184.0	1.00	257.6	1.40	2.30
		4.50		MHC19L	17.0	153.0	0.90	191.3	1.13	267.8	1.58	2.59
		5.00		MHC20L	14.4	144.0	1.00	180.0	1.25	252.0	1.75	2.88
		5.50		MHC21L	12.8	140.8	1.10	176.0	1.38	246.4	1.93	3.16
		6.00		MHC22L	12.0	144.0	1.20	180.0	1.50	252.0	2.10	3.45
		7.00		MHC23L	10.0	140.0	1.40	175.0	1.75	245.0	2.45	4.03
		8.00		MHC24L	8.8	140.8	1.60	176.0	2.00	246.4	2.80	4.60
12.00	MHC24AL	6.2	148.8	2.40	186.0	3.00	260.4	4.20	6.70			
1-1/4	5/8	1.50	0.165 X 0.270	MHC36L	113.4	340.2	0.30	425.3	0.38	595.4	0.53	0.92
		1.75		MHC36AL	94.5	330.8	0.35	413.4	0.44	578.8	0.61	1.07
		2.00		MHC37L	81.0	324.0	0.40	405.0	0.50	567.0	0.70	1.22
		2.50		MHC38L	62.4	312.0	0.50	390.0	0.63	546.0	0.88	1.55
		3.00		MHC39L	51.2	307.2	0.60	384.0	0.75	537.6	1.05	1.83
		3.50		MHC40L	43.5	304.5	0.70	380.6	0.88	532.9	1.23	2.12
		4.00		MHC41L	36.8	294.4	0.80	368.0	1.00	515.2	1.40	2.43
		4.50		MHC42L	32.0	288.0	0.90	360.0	1.13	504.0	1.58	2.68
		5.00		MHC43L	29.0	290.0	1.00	362.5	1.25	507.5	1.75	2.94
		5.50		MHC44L	26.4	290.4	1.10	363.0	1.38	508.2	1.93	3.22
		6.00		MHC45L	25.0	300.0	1.20	375.0	1.50	525.0	2.10	3.58
		7.00		MHC46L	20.0	280.0	1.40	350.0	1.75	490.0	2.45	4.10
		8.00		MHC47L	18.4	294.4	1.60	368.0	2.00	515.2	2.80	4.76
10.00	MHC48L	14.5	290.0	2.00	362.5	2.50	507.5	3.50	5.78			
12.00	MHC48AL	12.1	290.4	2.40	363.0	3.00	508.2	4.20	6.94			
1-1/2	3/4	2.00	0.191 X 0.320	MHC49L	104.0	416.0	0.40	520.0	0.50	728.0	0.70	1.21
		2.50		MHC50L	81.5	407.5	0.50	509.4	0.63	713.1	0.88	1.51
		3.00		MHC51L	62.4	374.4	0.60	468.0	0.75	655.2	1.05	1.75
		3.50		MHC52L	52.8	369.6	0.70	462.0	0.88	646.8	1.23	2.08
		4.00		MHC53L	47.3	378.4	0.80	473.0	1.00	662.2	1.40	2.31
		4.50		MHC54L	41.6	374.4	0.90	468.0	1.13	655.2	1.58	2.58
		5.00		MHC55L	36.8	368.0	1.00	460.0	1.25	644.0	1.75	2.82
		5.50		MHC55AL	33.6	369.6	1.10	462.0	1.38	646.8	1.93	3.05
		6.00		MHC56L	30.4	364.8	1.20	456.0	1.50	638.4	2.10	3.45
		7.00		MHC56AL	26.4	369.6	1.40	462.0	1.75	646.8	2.45	3.89
		8.00		MHC57L	22.0	352.0	1.60	440.0	2.00	616.0	2.80	4.45
		10.00		MHC58L	17.6	352.0	2.00	440.0	2.50	616.0	3.50	5.55
12.00	MHC58AL	14.4	345.6	2.40	432.0	3.00	604.8	4.20	6.80			
2	1	2.50	0.235 X 0.440	MHC70L	118.4	592.0	0.50	740.0	0.63	1036.0	0.88	1.47
		3.00		MHC71L	96.0	576.0	0.60	720.0	0.75	1008.0	1.05	1.77
		3.50		MHC72L	80.0	560.0	0.70	700.0	0.88	980.0	1.23	2.05
		4.00		MHC73L	66.4	531.2	0.80	664.0	1.00	929.6	1.40	2.32
		4.50		MHC74L	60.0	540.0	0.90	675.0	1.13	945.0	1.58	2.60
		5.00		MHC75L	55.1	551.0	1.00	688.8	1.25	964.3	1.75	2.92
		5.50		MHC76L	49.7	546.7	1.10	683.4	1.38	956.7	1.93	3.18
		6.00		MHC77L	45.3	543.6	1.20	679.5	1.50	951.3	2.10	3.46
		7.00		MHC79L	38.5	539.0	1.40	673.8	1.75	943.3	2.45	4.05
		8.00		MHC80L	33.5	536.0	1.60	670.0	2.00	938.0	2.80	4.62
		10.00		MHC82L	26.0	520.0	2.00	650.0	2.50	910.0	3.50	5.75
12.00	MHC83L	21.9	525.6	2.40	657.0	3.00	919.8	4.20	6.88			

* NOTE: For design purposes only. We do not recommend deflecting a spring to maximum deflection.

Heavy Duty Die Springs

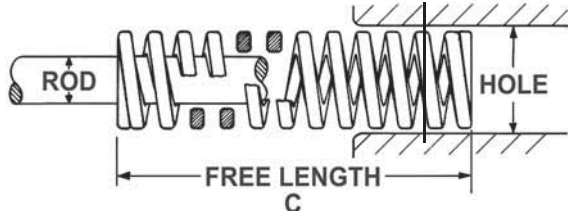

Color coded **GOLD STRIPE**

Hole Diam. (in)	Rod Diam. (in)	Free Length (in)	Wire Size (in)	CATALOG NUMBER	Pounds @ 1/10 inch defl.	Total Deflection Recommended for Long Life (15% of C)		Total Deflection Recommended for Avg. Life (20% of C)		Maximum Operating Deflection (28% of C)		* Max. Comp. Length (in)
						Load lbs.	Defl. in.	Load lbs.	Defl. in.	Load lbs.	Defl. in.	
3/8	3/16	1.00	0.053 X 0.071	H100L	11.6	17.4	0.15	23.2	0.20	32.5	0.28	0.65
		1.25		H100AL	9.8	18.4	0.19	24.5	0.25	34.3	0.35	0.79
		1.50		H101L	8.3	18.7	0.23	24.9	0.30	34.9	0.42	0.87
		1.75		H101AL	8.2	21.5	0.26	28.7	0.35	40.2	0.49	0.99
		2.00		H102L	7.1	21.3	0.30	28.4	0.40	39.8	0.56	1.14
		2.50		H103L	5.5	20.6	0.38	27.5	0.50	38.5	0.70	1.41
		3.00		H104L	4.2	18.9	0.45	25.2	0.60	35.3	0.84	1.72
		12.00		H105L	1.1	20.5	1.80	27.4	2.40	38.3	3.36	6.74
1/2	9/32	1.00	0.071 X 0.095	H110L	23.6	35.4	0.15	47.2	0.20	66.1	0.28	0.67
		1.25		H110AL	18.6	34.9	0.19	46.5	0.25	65.1	0.35	0.70
		1.50		H111L	15.5	34.9	0.23	46.5	0.30	65.1	0.42	0.81
		1.75		H111AL	13.8	36.2	0.26	48.3	0.35	67.6	0.49	1.00
		2.00		H112L	11.0	33.0	0.30	44.0	0.40	61.6	0.56	1.05
		2.50		H113L	8.4	31.5	0.38	42.0	0.50	58.8	0.70	1.32
		3.00		H114L	7.4	33.3	0.45	44.4	0.60	62.2	0.84	1.54
		3.50		H115L	6.0	31.5	0.53	42.0	0.70	58.8	0.98	1.82
12.00	H117L	1.6	28.8	1.80	38.4	2.40	53.8	3.36	6.28			
5/8	11/32	1.00	0.096 X 0.115	H120L	43.0	64.5	0.15	86.0	0.20	120.4	0.28	0.62
		1.25		H120AL	32.0	60.0	0.19	80.0	0.25	112.0	0.35	0.78
		1.50		H121L	27.7	62.3	0.23	83.1	0.30	116.3	0.42	0.90
		1.75		H121AL	24.0	63.0	0.26	84.0	0.35	117.6	0.49	1.01
		2.00		H122L	20.8	62.4	0.30	83.2	0.40	116.5	0.56	1.18
		2.50		H123L	16.6	62.3	0.38	83.0	0.50	116.2	0.70	1.44
		3.00		H124L	14.0	63.0	0.45	84.0	0.60	117.6	0.84	1.68
		3.50		H125L	11.9	62.5	0.53	83.3	0.70	116.6	0.98	1.95
4.00	H126L	10.4	62.4	0.60	83.2	0.80	116.5	1.12	2.22			
12.00	H127L	3.1	55.8	1.80	74.4	2.40	104.2	3.36	6.60			
3/4	3/8	1.00	0.130 X 0.155	H1L	108.8	163.2	0.15	217.6	0.20	304.6	0.28	0.69
		1.25		H1AL	88.0	165.0	0.19	220.0	0.25	308.0	0.35	0.86
		1.50		H2L	68.4	153.9	0.23	205.2	0.30	287.3	0.42	1.02
		1.75		H2AL	60.0	157.5	0.26	210.0	0.35	294.0	0.49	1.19
		2.00		H3L	49.8	149.4	0.30	199.2	0.40	278.9	0.56	1.35
		2.50		H4L	40.0	150.0	0.38	200.0	0.50	280.0	0.70	1.71
		3.00		H5L	34.0	153.0	0.45	204.0	0.60	285.6	0.84	2.00
		3.50		H6L	28.0	147.0	0.53	196.0	0.70	274.4	0.98	2.33
		4.00		H7L	25.0	150.0	0.60	200.0	0.80	280.0	1.12	2.67
		4.50		H8L	22.0	148.5	0.68	198.0	0.90	277.2	1.26	3.00
		5.00		H9L	19.5	146.3	0.75	195.0	1.00	273.0	1.40	3.33
		5.50		H10L	17.0	140.3	0.83	187.0	1.10	261.8	1.54	3.66
6.00	H11L	16.0	144.0	0.90	192.0	1.20	268.8	1.68	3.99			
12.00	H11AL	8.0	144.0	1.80	192.0	2.40	268.8	3.36	7.90			

* NOTE: For design purposes only. We do not recommend deflecting a spring to maximum deflection.

Inch Standard

Hole Diam. (in)	Rod Diam. (in)	Free Length (in)	Wire Size (in)	CATALOG NUMBER	Pounds @ 1/10 inch defl.	Total Deflection Recommended for Long Life (15% of C)		Total Deflection Recommended for Avg. Life (20% of C)		Maximum Operating Deflection (28% of C)		* Max. Comp. Length (in)
						Load lbs.	Defl. in.	Load lbs.	Defl. in.	Load lbs.	Defl. in.	
1	1/2	1.00	0.165 X 0.216	H12L	208.0	312.0	0.15	416.0	0.20	582.4	0.28	0.68
		1.25		H12AL	170.0	318.8	0.19	425.0	0.25	595.0	0.35	0.86
		1.50		H13L	119.8	269.6	0.23	359.4	0.30	503.2	0.42	1.03
		1.75		H13AL	104.0	273.0	0.26	364.0	0.35	509.6	0.49	1.18
		2.00		H14L	90.0	270.0	0.30	360.0	0.40	504.0	0.56	1.35
		2.50		H15L	68.0	255.0	0.38	340.0	0.50	476.0	0.70	1.68
		3.00		H16L	54.4	244.8	0.45	326.4	0.60	457.0	0.84	2.00
		3.50		H17L	45.9	241.0	0.53	321.3	0.70	449.8	0.98	2.33
		4.00		H18L	40.0	240.0	0.60	320.0	0.80	448.0	1.12	2.63
		4.50		H19L	35.2	237.6	0.68	316.8	0.90	443.5	1.26	2.94
		5.00		H20L	31.5	236.3	0.75	315.0	1.00	441.0	1.40	3.26
		5.50		H20AL	28.8	237.6	0.83	316.8	1.10	443.5	1.54	3.55
		6.00		H21L	25.9	233.1	0.90	310.8	1.20	435.1	1.68	3.87
		7.00		H21AL	22.4	235.2	1.05	313.6	1.40	439.0	1.96	4.47
8.00	H22L	19.2	230.4	1.20	307.2	1.60	430.1	2.24	5.16			
12.00	H22AL	12.5	225.0	1.80	300.0	2.40	420.0	3.36	7.80			
1-1/4	5/8	1.50	0.209 X 0.275	H36L	212.0	477.0	0.23	636.0	0.30	890.4	0.42	1.01
		1.75		H36AL	181.0	475.1	0.26	633.5	0.35	886.9	0.49	1.17
		2.00		H37L	149.6	448.8	0.30	598.4	0.40	837.8	0.56	1.34
		2.50		H38L	117.2	439.5	0.38	586.0	0.50	820.4	0.70	1.68
		3.00		H39L	95.0	427.5	0.45	570.0	0.60	798.0	0.84	2.02
		3.50		H40L	77.0	404.3	0.53	539.0	0.70	754.6	0.98	2.30
		4.00		H41L	66.4	398.4	0.60	531.2	0.80	743.7	1.12	2.66
		4.50		H42L	58.4	394.2	0.68	525.6	0.90	735.8	1.26	2.99
		5.00		H43L	53.0	397.5	0.75	530.0	1.00	742.0	1.40	3.30
		5.50		H44L	47.2	389.4	0.83	519.2	1.10	726.9	1.54	3.62
		6.00		H45L	42.9	386.1	0.90	514.8	1.20	720.7	1.68	3.95
		7.00		H46L	36.8	386.4	1.05	515.2	1.40	721.3	1.96	4.60
		8.00		H47L	32.8	393.6	1.20	524.8	1.60	734.7	2.24	5.25
		10.00		H48L	25.6	384.0	1.50	512.0	2.00	716.8	2.80	6.40
12.00	H48AL	20.8	374.4	1.80	499.2	2.40	698.9	3.36	7.62			
1-1/2	3/4	2.00	0.245 X 0.328	H49L	195.4	586.2	0.30	781.6	0.40	1094.2	0.56	1.34
		2.50		H50L	155.0	581.3	0.38	775.0	0.50	1085.0	0.70	1.68
		3.00		H51L	128.0	576.0	0.45	768.0	0.60	1075.2	0.84	1.99
		3.50		H52L	106.4	558.6	0.53	744.8	0.70	1042.7	0.98	2.30
		4.00		H53L	91.2	547.2	0.60	729.6	0.80	1021.4	1.12	2.62
		4.50		H54L	78.4	529.2	0.68	705.6	0.90	987.8	1.26	2.91
		5.00		H55L	71.2	534.0	0.75	712.0	1.00	996.8	1.40	3.22
		5.50		H55AL	64.0	528.0	0.83	704.0	1.10	985.6	1.54	3.54
		6.00		H56L	58.4	525.6	0.90	700.8	1.20	981.1	1.68	3.82
		7.00		H56AL	49.6	520.8	1.05	694.4	1.40	972.2	1.96	4.44
		8.00		H57L	43.2	518.4	1.20	691.2	1.60	967.7	2.24	5.02
		10.00		H58L	34.4	516.0	1.50	688.0	2.00	963.2	2.80	6.26
		12.00		H58AL	28.8	518.4	1.80	691.2	2.40	967.7	3.36	7.50
		2		1	2.50	.305 X 0.450	H70L	253.0	948.8	0.38	1265.0	0.50
3.00	H71L		200.0		900.0		0.45	1200.0	0.60	1680.0	0.84	2.05
3.50	H72L		170.0		892.5		0.53	1190.0	0.70	1666.0	0.98	2.37
4.00	H73L		146.0		876.0		0.60	1168.0	0.80	1635.2	1.12	2.67
4.50	H74L		120.0		810.0		0.68	1080.0	0.90	1512.0	1.26	2.98
5.00	H75L		110.0		825.0		0.75	1100.0	1.00	1540.0	1.40	3.32
5.50	H76L		100.0		825.0		0.83	1100.0	1.10	1540.0	1.54	3.65
6.00	H77L		93.0		837.0		0.90	1116.0	1.20	1562.4	1.68	3.97
7.00	H79L		79.0		829.5		1.05	1106.0	1.40	1548.4	1.96	4.61
8.00	H80L		69.0		828.0		1.20	1104.0	1.60	1545.6	2.24	5.22
10.00	H82L		54.4		816.0		1.50	1088.0	2.00	1523.2	2.80	6.55
12.00	H83L		42.0		756.0		1.80	1008.0	2.40	1411.2	3.36	7.75

* NOTE: For design purposes only. We do not recommend deflecting a spring to maximum deflection.

Extra Heavy Duty Die Springs

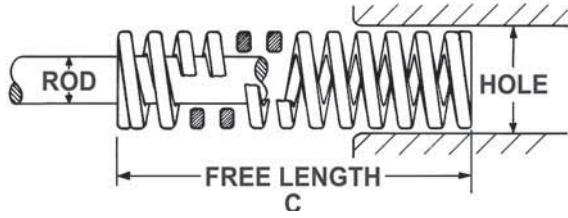

Color coded **GREEN STRIPE**

Hole Diam. (in)	Rod Diam. (in)	Free Length (in)	Wire Size (in)	CATALOG NUMBER	Pounds @ 1/10 inch defl.	Total Deflection Recommended for Long Life (15% of C)		Total Deflection Recommended for Avg. Life (17% of C)		Maximum Operating Deflection (25% of C)		* Max. Comp. Length (in)
						Load lbs.	Defl. in.	Load lbs.	Defl. in.	Load lbs.	Defl. in.	
3/8	3/16	1.00	0.063 X 0.073	XH100L	20.5	30.8	0.15	34.9	0.17	51.3	0.25	0.67
		1.25		XH100AL	16.0	30.0	0.19	34.0	0.21	50.0	0.31	0.86
		1.50		XH101L	12.5	28.1	0.23	31.9	0.26	46.9	0.38	1.03
		1.75		XH101AL	11.1	29.1	0.26	33.0	0.30	48.6	0.44	1.22
		2.00		XH102L	9.0	27.0	0.30	30.6	0.34	45.0	0.50	1.38
		2.50		XH103L	7.0	26.3	0.38	29.8	0.43	43.8	0.63	1.71
		3.00		XH104L	6.3	28.4	0.45	32.1	0.51	47.3	0.75	2.05
		12.00		XH105L	1.5	27.0	1.80	30.6	2.04	45.0	3.00	7.98
1/2	9/32	1.00	0.088 X 0.090	XH110L	32.0	48.0	0.15	54.4	0.17	80.0	0.25	0.69
		1.25		XH110AL	24.2	45.4	0.19	51.4	0.21	75.6	0.31	0.86
		1.50		XH111L	20.0	45.0	0.23	51.0	0.26	75.0	0.38	1.03
		1.75		XH111AL	17.0	44.6	0.26	50.6	0.30	74.4	0.44	1.20
		2.00		XH112L	14.5	43.5	0.30	49.3	0.34	72.5	0.50	1.36
		2.50		XH113L	11.5	43.1	0.38	48.9	0.43	71.9	0.63	1.65
		3.00		XH114L	9.4	42.3	0.45	47.9	0.51	70.5	0.75	1.99
		3.50		XH115L	8.0	42.0	0.53	47.6	0.60	70.0	0.88	2.30
12.00	XH116L	2.5	45.0	1.80	51.0	2.04	75.0	3.00	7.82			
5/8	11/32	1.00	0.115 X 0.120	XH120L	63.0	94.5	0.15	107.1	0.17	157.5	0.25	0.68
		1.25		XH120AL	47.0	88.1	0.19	99.9	0.21	146.9	0.31	0.85
		1.50		XH121L	38.0	85.5	0.23	96.9	0.26	142.5	0.38	1.03
		1.75		XH121AL	32.0	84.0	0.26	95.2	0.30	140.0	0.44	1.20
		2.00		XH122L	29.0	87.0	0.30	98.6	0.34	145.0	0.50	1.38
		2.50		XH123L	22.0	82.5	0.38	93.5	0.43	137.5	0.63	1.81
		3.00		XH124L	19.0	85.5	0.45	96.9	0.51	142.5	0.75	2.06
		3.50		XH125L	16.0	84.0	0.53	95.2	0.60	140.0	0.88	2.39
4.00	XH126L	13.5	81.0	0.60	91.8	0.68	135.0	1.00	2.78			
12.00	XH127L	4.5	81.0	1.80	91.8	2.04	135.0	3.00	7.87			
3/4	3/8	1.00	0.140 X 0.155	XH1L	140.0	210.0	0.15	238.0	0.17	350.0	0.25	0.71
		1.25		XH1AL	110.0	206.3	0.19	233.8	0.21	343.8	0.31	0.89
		1.50		XH2L	89.0	200.3	0.23	227.0	0.26	333.8	0.38	1.06
		1.75		XH2AL	75.0	196.9	0.26	223.1	0.30	328.1	0.44	1.24
		2.00		XH3L	68.0	204.0	0.30	231.2	0.34	340.0	0.50	1.42
		2.50		XH4L	50.0	187.5	0.38	212.5	0.43	312.5	0.63	1.76
		3.00		XH5L	40.5	182.3	0.45	206.6	0.51	303.8	0.75	2.07
		3.50		XH6L	34.5	181.1	0.53	205.3	0.60	301.9	0.88	2.41
		4.00		XH7L	30.0	180.0	0.60	204.0	0.68	300.0	1.00	2.76
		4.50		XH8L	26.5	178.9	0.68	202.7	0.77	298.1	1.13	3.10
		5.00		XH9L	23.5	176.3	0.75	199.8	0.85	293.8	1.25	3.42
		5.50		XH10L	21.5	177.4	0.83	201.0	0.94	295.6	1.38	3.78
6.00	XH11L	19.5	175.5	0.90	198.9	1.02	292.5	1.50	4.10			
12.00	XH12L	9.5	171.0	1.80	193.8	2.04	285.0	3.00	8.10			

* NOTE: For design purposes only. We do not recommend deflecting a spring to maximum deflection.

Inch Standard

Hole Diam. (in)	Rod Diam. (in)	Free Length (in)	Wire Size (in)	CATALOG NUMBER	Pounds @ 1/10 inch defl.	Total Deflection Recommended for Long Life (15% of C)		Total Deflection Recommended for Avg. Life (17% of C)		Maximum Operating Deflection (25% of C)		* Max. Comp. Length (in)
						Load lbs.	Defl. in.	Load lbs.	Defl. in.	Load lbs.	Defl. in.	
1	1/2	1.50	0.182 X 0.215	XH13L	160.0	360.0	0.23	408.0	0.26	600.0	0.38	1.05
		2.00		XH14L	116.0	348.0	0.30	394.4	0.34	580.0	0.50	1.40
		2.50		XH15L	89.6	336.0	0.38	380.8	0.43	560.0	0.63	1.73
		3.00		XH16L	73.6	331.2	0.45	375.4	0.51	552.0	0.75	2.08
		3.50		XH17L	62.4	327.6	0.53	371.3	0.60	546.0	0.88	2.42
		4.00		XH18L	55.2	331.2	0.60	375.4	0.68	552.0	1.00	2.74
		4.50		XH19L	48.8	329.4	0.68	373.3	0.77	549.0	1.13	3.04
		5.00		XH20L	43.2	324.0	0.75	367.2	0.85	540.0	1.25	3.38
		6.00		XH21L	36.0	324.0	0.90	367.2	1.02	540.0	1.50	3.99
		12.00		XH22AL	17.6	316.8	1.80	359.0	2.04	528.0	3.00	7.86
1-1/4	5/8	2.00	0.226 X 0.280	XH37L	192.0	576.0	0.30	652.8	0.34	960.0	0.50	1.41
		2.50		XH38L	146.2	548.3	0.38	621.4	0.43	913.8	0.63	1.74
		3.00		XH39L	118.4	532.8	0.45	603.8	0.51	888.0	0.75	2.09
		3.50		XH40L	100.8	529.2	0.53	599.8	0.60	882.0	0.88	2.43
		4.00		XH41L	85.0	510.0	0.60	578.0	0.68	850.0	1.00	2.78
		4.50		XH42L	78.4	529.2	0.68	599.8	0.77	882.0	1.13	3.12
		5.00		XH43L	68.0	510.0	0.75	578.0	0.85	850.0	1.25	3.46
		6.00		XH45L	56.0	504.0	0.90	571.2	1.02	840.0	1.50	4.11
		8.00		XH47L	41.6	499.2	1.20	565.8	1.36	832.0	2.00	5.40
		10.00		XH48L	33.6	504.0	1.50	571.2	1.70	840.0	2.50	6.75
12.00	XH48AL	26.4	475.2	1.80	538.6	2.04	792.0	3.00	7.99			
1-1/2	3/4	2.00	0.290 X 0.330	XH49L	370.0	1017.0	0.30	1152.6	0.34	1695.0	0.50	1.45
		2.50		XH50L	285.0	993.8	0.38	1126.3	0.43	1656.3	0.63	1.80
		3.00		XH51L	231.2	967.5	0.45	1096.5	0.51	1612.5	0.75	2.16
		3.50		XH52L	196.0	918.8	0.53	1041.3	0.60	1531.3	0.88	2.51
		4.00		XH53L	171.0	912.0	0.60	1033.6	0.68	1520.0	1.00	2.90
		4.50		XH54L	148.0	891.0	0.68	1009.8	0.77	1485.0	1.13	3.22
		5.00		XH55L	135.0	915.0	0.75	1037.0	0.85	1525.0	1.25	3.58
		6.00		XH56L	110.4	891.0	0.90	1009.8	1.02	1485.0	1.50	4.30
		8.00		XH57L	80.8	852.0	1.20	965.6	1.36	1420.0	2.00	5.72
		10.00		XH58L	65.0	855.0	1.50	969.0	1.70	1425.0	2.50	7.12
12.00	XH58AL	54.0	828.0	1.80	938.4	2.04	1380.0	3.00	8.52			
2	1	2.50	0.350 X 0.452	XH70L	387.0	1451.3	0.38	1644.8	0.43	2418.8	0.63	1.81
		3.00		XH71L	312.0	1404.0	0.45	1591.2	0.51	2340.0	0.75	2.16
		3.50		XH72L	254.4	1335.6	0.53	1513.7	0.60	2226.0	0.88	2.51
		4.00		XH73L	220.0	1320.0	0.60	1496.0	0.68	2200.0	1.00	2.86
		4.50		XH74L	189.7	1280.5	0.68	1451.2	0.77	2134.1	1.13	3.21
		5.00		XH75L	172.8	1296.0	0.75	1468.8	0.85	2160.0	1.25	3.56
		6.00		XH77L	141.6	1274.4	0.90	1444.3	1.02	2124.0	1.50	4.24
		8.00		XH80L	101.5	1218.0	1.20	1380.4	1.36	2030.0	2.00	5.64
		10.00		XH82L	84.0	1260.0	1.50	1428.0	1.70	2100.0	2.50	7.02
		12.00		XH83L	70.0	1260.0	1.80	1428.0	2.04	2100.0	3.00	8.35

* NOTE: For design purposes only. We do not recommend deflecting a spring to maximum deflection.

Spring Accessories

Spring Cages

- ◆ Our spring cages enhance die spring life by providing a flat, hardened die pocket for spring operation.
- ◆ Material: A513 tube steel.
- ◆ Conforms to NAAMS standards.

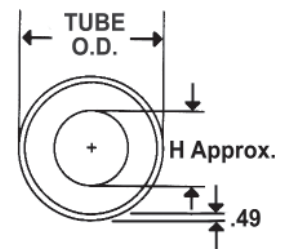
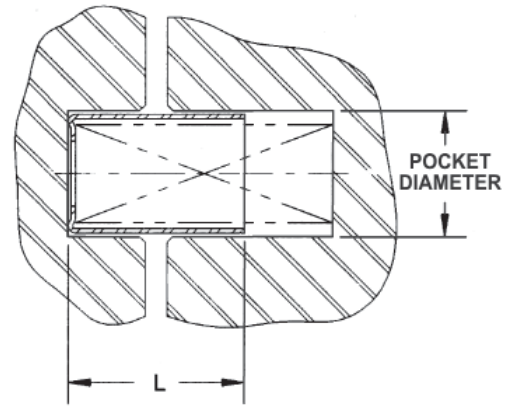

Spring Diameter (in)	Pocket Diameter (in)	Tube O.D. (in)	Diameter (H) (in)
3/4	29/32	0.855	7/16
1	1-5/32	1.105	9/16
1-1/4	1-13/32	1.355	3/4
1-1/2	1-21/32	1.605	31/32
2	2-5/32	2.105	1-3/8

Length L (in)	3/4 inch Diameter Springs		1 inch Diameter Springs		1-1/4 inch Diameter Springs		1-1/2 inch Diameter Springs		2 inch Diameter Springs	
	CATALOG NUMBER	NAAMS Code	CATALOG NUMBER	NAAMS Code	CATALOG NUMBER	NAAMS Code	CATALOG NUMBER	NAAMS Code	CATALOG NUMBER	NAAMS Code
1	LSC0608	S212025	LSC0808	S212525	LSC1008	S213225	LSC1208	S214025	LSC1608	S215025
1-1/4	LSC0610	S212032	LSC0810	S212532	LSC1010	S213232	LSC1210	S214032	LSC1610	S215032
1-1/2	LSC0612	S212038	LSC0812	S212538	LSC1012	S213238	LSC1212	S214038	LSC1612	S215038
1-3/4	LSC0614	S212044	LSC0814	S212544	LSC1014	S213244	LSC1214	S214044	LSC1614	S215044
2	LSC0616	S212051	LSC0816	S212551	LSC1016	S213251	LSC1216	S214051	LSC1616	S215051
2-1/4	LSC0618	-	LSC0818	-	LSC1018	-	LSC1218	-	LSC1618	-
2-1/2	LSC0620	S212064	LSC0820	S212564	LSC1020	S213264	LSC1220	S214064	LSC1620	S215064
2-3/4	LSC0622	-	LSC0822	-	LSC1022	-	LSC1222	-	LSC1622	-
3	LSC0624	S212076	LSC0824	S212576	LSC1024	S213276	LSC1224	S214076	LSC1624	S215076
3-1/4	LSC0626	-	LSC0826	-	LSC1026	-	LSC1226	-	LSC1626	-
3-1/2	LSC0628	S212089	LSC0828	S212589	LSC1028	S213289	LSC1228	S214089	LSC1628	S215089
3-3/4	LSC0630	-	LSC0830	-	LSC1030	-	LSC1230	-	LSC1630	-
4	LSC0632	S212010	LSC0832	S212510	LSC1032	S213210	LSC1232	S214010	LSC1632	S215010
4-1/4	LSC0634	-	LSC0834	-	LSC1034	-	LSC1234	-	LSC1634	-
4-1/2	LSC0636	-	LSC0836	-	LSC1036	-	LSC1236	-	LSC1636	-
4-3/4	LSC0638	-	LSC0838	-	LSC1038	-	LSC1238	-	LSC1638	-
5	LSC0640	S212012	LSC0840	S212512	LSC1040	S213212	LSC1240	S214012	LSC1640	S215012
5-1/2	LSC0644	-	LSC0844	-	LSC1044	-	LSC1244	-	LSC1644	-
6	LSC0648	S212015	LSC0848	S212515	LSC1048	S213215	LSC1248	S214015	LSC1648	S215015
6-1/2	LSC0652	-	LSC0852	-	LSC1052	-	LSC1252	-	LSC1652	-
7	LSC0656	S212017	LSC0856	S212517	LSC1056	S213217	LSC1256	S214017	LSC1656	S215017
8	LSC0664	S212020	LSC0864	S212520	LSC1064	S213220	LSC1264	S214020	LSC1664	S215020
9	-	-	-	-	LSC1072	S213222	LSC1272	S214022	LSC1672	S215022
10	-	-	-	-	LSC1080	-	LSC1280	-	LSC1680	-
11	-	-	-	-	-	-	-	-	LSC1688	S215028
12	-	-	-	-	-	-	-	-	LSC1696	S215030

Spring Accessories

Spring Retainers

- ◆ These spring retainers hold individual springs firmly in position while the die is being assembled or disassembled. Pre-loading the spring is easy since the springs can be set individually, which avoids working against the combined force of the springs.
- ◆ Available for springs 1-1/4" (32mm), 1-1/2" (38mm) and 2" (50mm) diameters and any free length where clearance permits.
- ◆ Material: steel

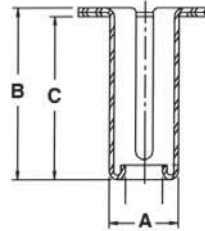
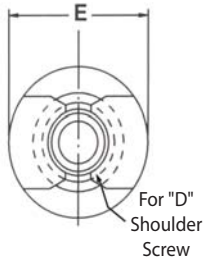
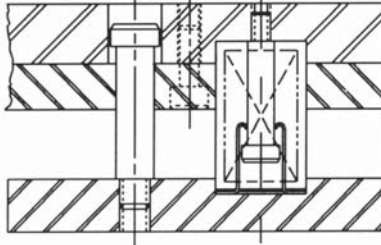

Catalog Number	Spring Diameter		Rod Diameter A		B		C		Shoulder Screw D		E	
	in	mm	in	mm	in	mm	in	mm	in	mm	in	mm
9-0615-16	1-1/2	38	3/4	19	1-7/8	48	1-3/4	44	3/8	—	1-7/16	37
9-0815-16	2	51	1	25	1-3/4	48	1-3/4	44	1/2	M12	1-5/16	33
9-0823-16	2	51	1	25	2-7/8	73	2-3/4	70	1/2	M12	1-5/16	33

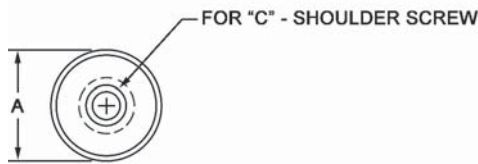
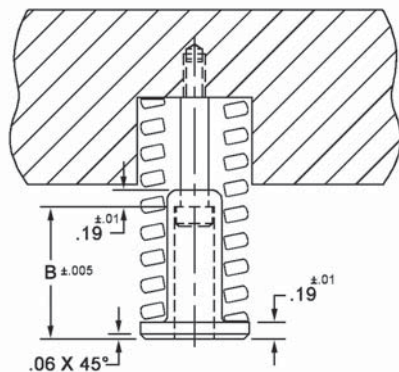

Catalog Number	Spring Diameter		Rod Diameter A		B		C		Shoulder Screw D		E	
	in	mm	in	mm	in	mm	in	mm	in	mm	in	mm
SR125150	1-1/4	32	5/8	16	1-11/16	43	1-1/2	38	5/16	M8	1-1/4	32
SR125200					2-3/16	56	2	51	5/16	M8	1-1/4	32
SR125250					2-11/16	68	2-1/2	64	5/16	M8	1-1/4	32
SR150150	1-1/2	38	3/4	19	1-11/16	43	1-1/2	38	3/8	M10	1-1/2	38
SR150200					2-3/16	56	2	51	3/8	M10	1-1/2	38
SR150250					2-11/16	68	2-1/2	64	3/8	M10	1-1/2	38
SR200150	2	51	1	25	1-11/16	43	1-1/2	38	1/2	M13	2	51
SR200200					2-3/16	56	2	51	1/2	M13	2	51
SR200250					2-11/16	68	2-1/2	64	1/2	M13	2	51

Special Heavy Duty Compression Springs

CUSTOM SPRINGS

A custom spring is any spring that has:

- ◆ Unique physical attributes
 - Special wire material, plating or paint
 - Custom free lengths, diameters, solid heights, rates, number of coils or custom loads at a given deflection
- ◆ Critical tolerances
- ◆ Specific inspection or certification requirements
 - Military specifications
 - 100% inspection of critical characteristics
- ◆ Statistical reports
- ◆ Computer controlled multi-point tests

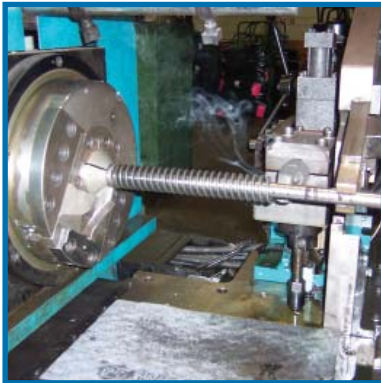

MANUFACTURING CAPABILITIES

- ◆ Outside diameters from 3/16" to 9-1/2" (4.8mm to 241mm)
- ◆ Free length from 1/2" to 90" (12.5mm to 2286mm)
- ◆ Round Spring wire 0.014" minimum to 1.625" (.36mm to 41.3mm)
- ◆ Standard rectangular wire up to 0.408" x 0.469" (10.4mm to 11.9mm)

Modified trapezoidal cross section of rectangular wire springs changes to a "D" cross section during coiling to achieve a low stress level that means longer spring life.

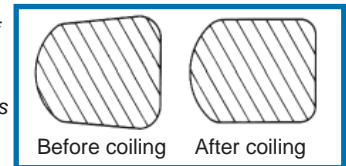

COATINGS AVAILABLE

- ◆ Plain, no paint
- ◆ Oiled
- ◆ Electroless Nickel
- ◆ Chrome
- ◆ Zinc
- ◆ Powder Coating
- ◆ E-coat Paint
- ◆ Mil-spec Coatings
- ◆ Cadmium
- ◆ Dacromet®
- ◆ Others on request

SPRING SPECIALS QUOTING PROCESS

- ◆ Submit custom spring print
- ◆ Submit application information
 - Include description of application
 - Life expectations
 - Critical dimensions, tolerances, certifications required



Other Anchor Lamina Products

Anchor Lamina supplies the most extensive selection of springs and pressure control devices used in die sets, molds, fixtures and machines. Among the products Anchor Lamina stocks are the following:



Disc Springs

- ◆ Efficient use of space, providing high spring forces with small deflections
- ◆ May be used in series or parallel
- ◆ Available in a variety of sizes



Formathane® Urethane

- ◆ Specially formulated for metalforming
- ◆ Greater abrasion resistance
- ◆ Higher pressures with added durability



Marsh Mellow® Die Springs

- ◆ An effective alternative to costly nitrogen gas springs
- ◆ Widely used in the automotive and metal stamping industries
- ◆ Available from 1-1/8" to 6" O.D.



MRO Utility Springs

- ◆ Engineered for durability
- ◆ Unlimited applications for general utility and industry
- ◆ Available in assortments

Distributed by:



Lamina Components

38505 Country Club Drive Suite 100

Farmington Hills, MI USA 48331

Tel: 248-489-9122, 800-652-6462;

Fax: 248-553-6842, 800-406-4410

E-Mail: sales@lamina.com

www.anchorlamina.com

